



PRESENTATION PRODUIT

NOUVEAU BERLINGO

NOUVEAU SUV C5 AIRCROSS

SOCHAUX - 31 OCTOBRE 2018

Inspired by you

Nouveau Berlingo VP & VU



DI / BU VU

VVA

Confidentiel – C3

K9 - PROGRAM OVERVIEW

3rd GEN. OF BERLINGO / PARTNER

5th GEN. OF COMBO

BRANDS



PLANTS



VIGO



MANGUALDE

DO YOU KNOW THAT ...

Renewing the segment's leader ...
... and increasing profitability !



2017

... Over **3 500 000** cars on road today

... **Best selling year** - 9 year after SOP (308 569 units)

... Brand's champion on **17** countries for **AC** (*UK, Germany, Spain, Sweden...*)
11 countries for **AP** (*Poland, Chile, Algeria, Mexico...*)

... €30 market share :
LCV : **32,5%**
PC : **31,9%**

COMPETITORS PLANNING

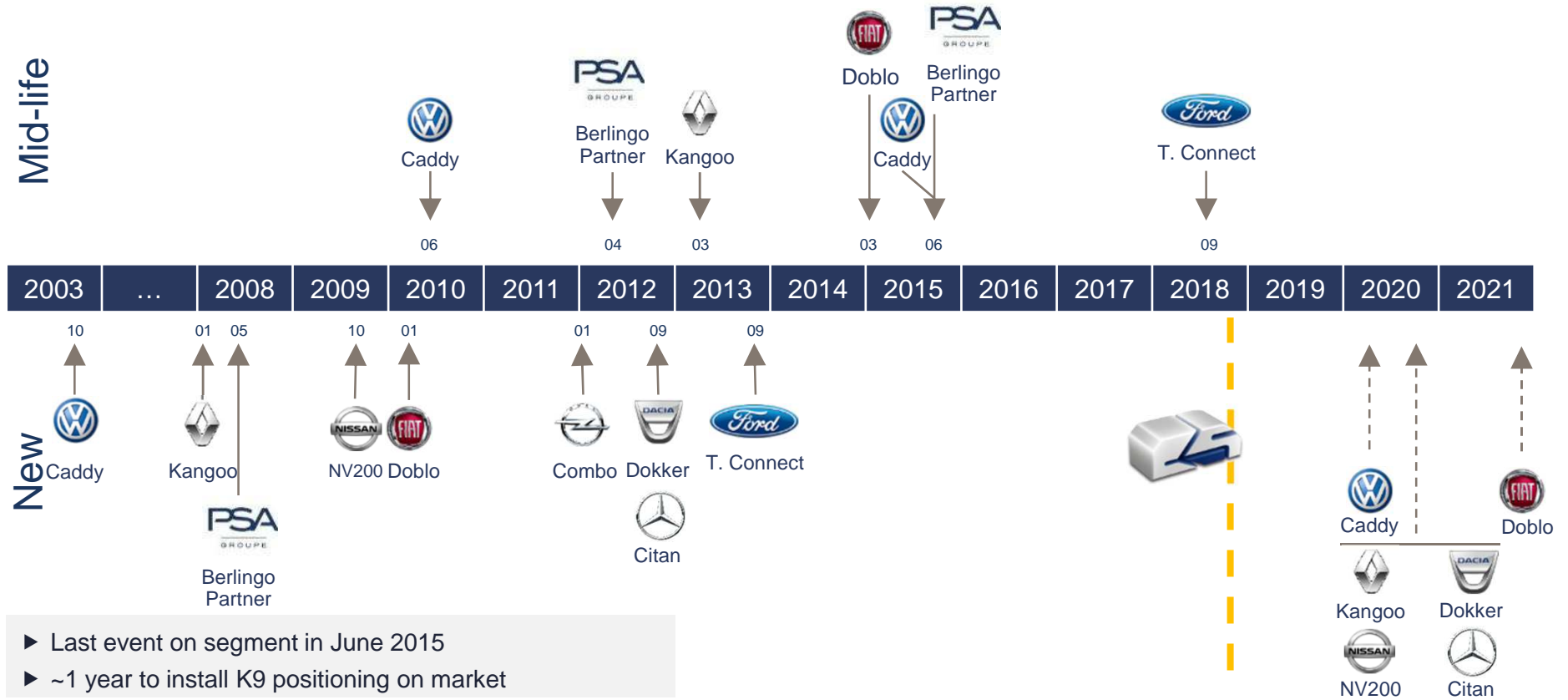

DARWIN'S THEORY

New generation, new Concept !

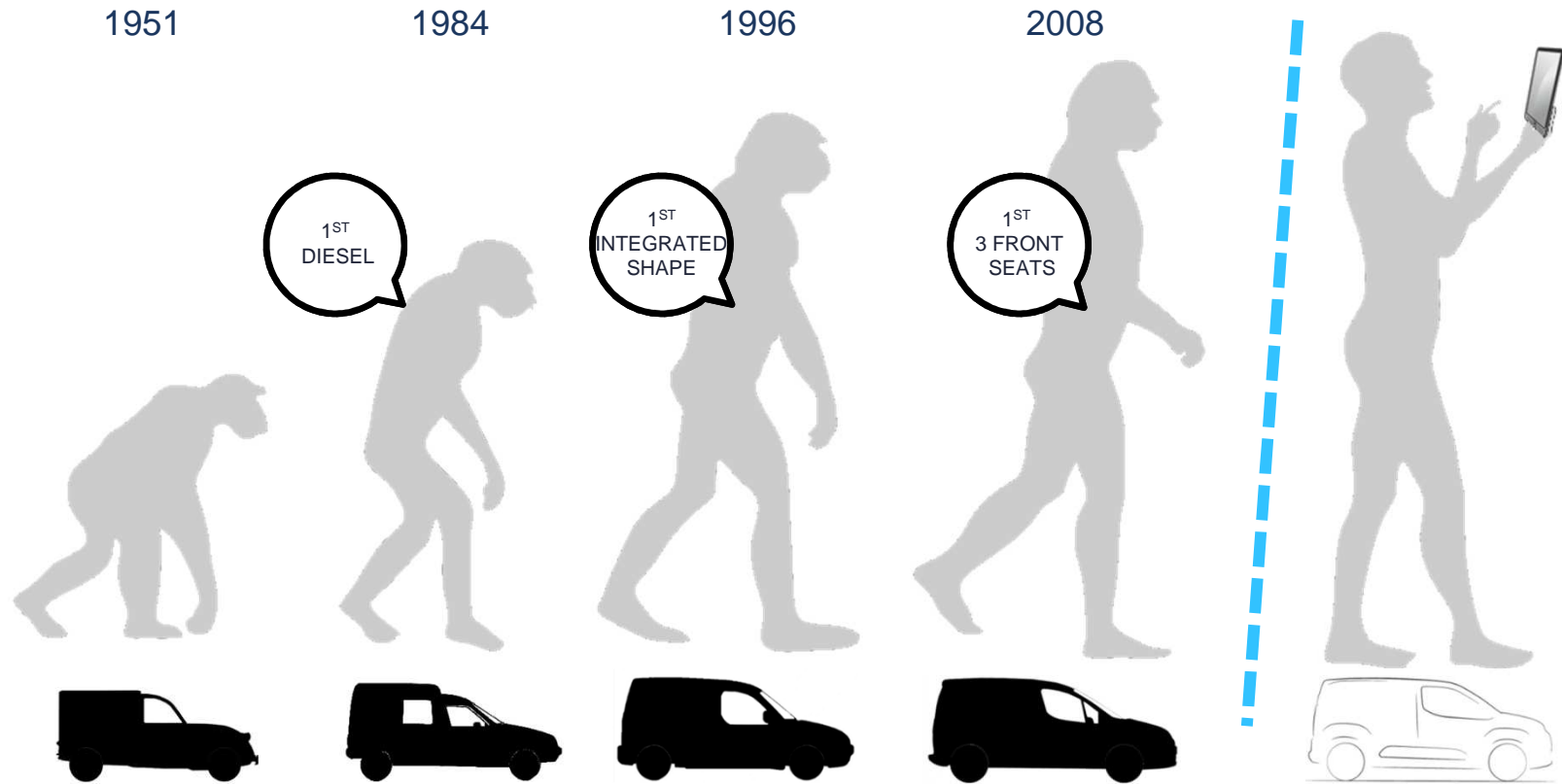

K9 PLATFORM

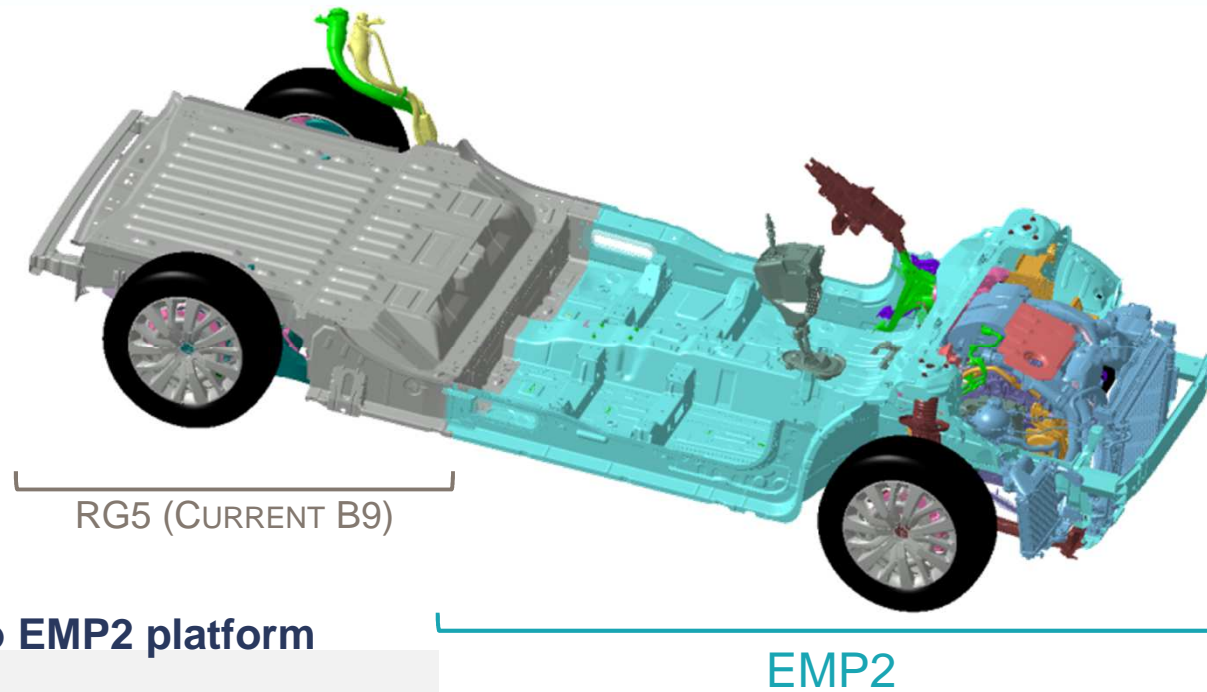

Benefits thanks to EMP2 platform

- ▶ Short over hang
- ▶ Maneuverability (electric power steering, turning radius)
- ▶ Weight reduction
- ▶ ADAS

K9 – LENGTH 1

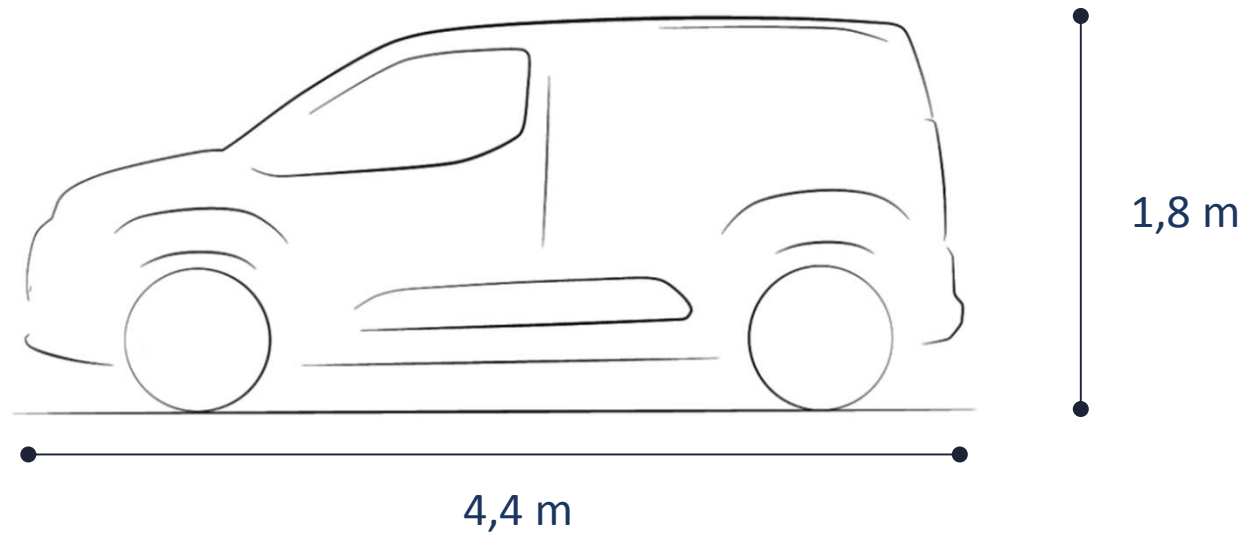

K9 – LENGTH 2

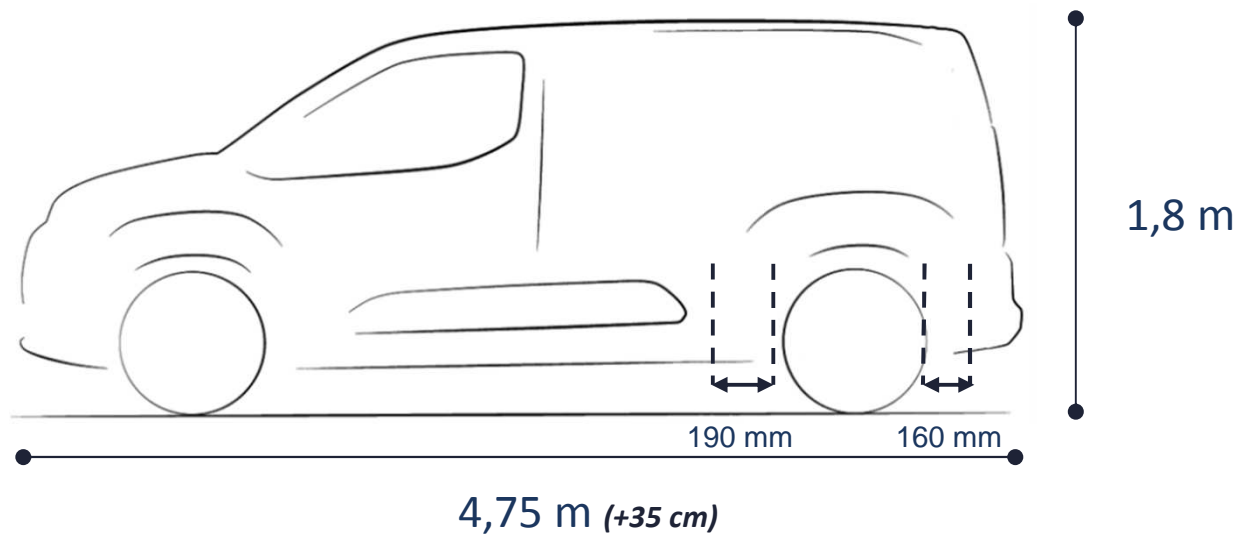

K9 vs B9

Do a split ! Justified by volume and export !

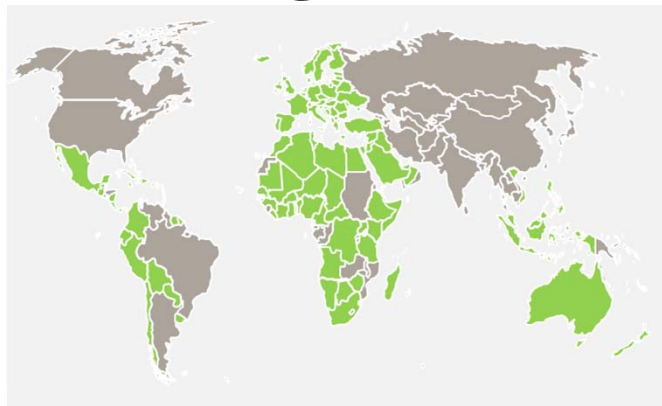
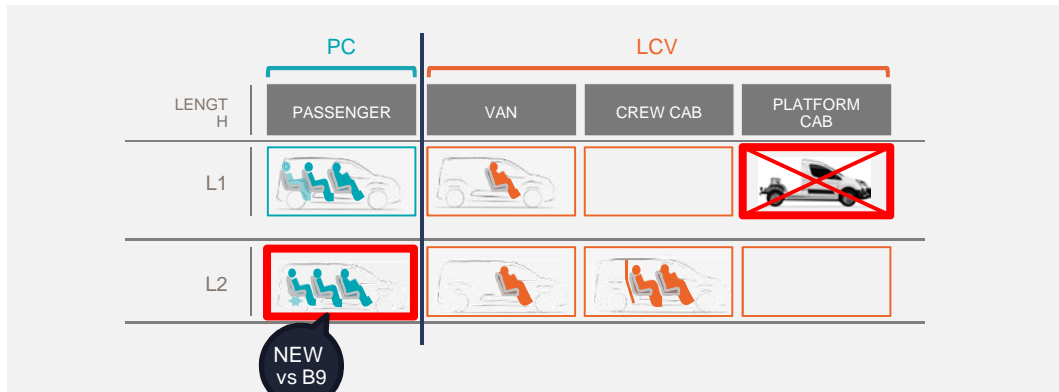

- B9 :**
- 88 pays
- K9 :**
- 117 pays

	B9	K9	Commentaires
ADAS			
Safety Pack (LKA, SLI/ISA, V-AEB)	✗	✓	eNCAP 2018 4*
ACC-Video, Citypark2	✗	✓	Pas d'enjeux diversité / PRF. Politique déploiement ADAS
Citypark2	✗	✓	Pas d'enjeux diversité / PRF. Politique déploiement ADAS
Blind Spot Detection	✗	✓	Politique déploiement ADAS
Dynamic Surrounding View	✗	✓	USP VU K9
Indicateur de surcharge	✗	✓	USP VU K9
VTH	✗	✓	Attractivité AC vs I-Cockpit, cohérence K0.
FSE	✗	✓	Optimisation 3pl. Avant VU, prestation VU (métiers urbains), modernité VP.
Equipements / infotainment			
Recharge nomade	✗	✓	marché des années 2020
VCI	✗	✓	Cohérence de gamme PSA. Attendu marchés.
ADML	✗	✓	Cohérence de gamme PSA. Attendu marchés.
Look			
Différenciations marque (Grandes roues, passages de roues, face avant différenciées, barres de toit par marques, feux, projecteurs, i-cockpit)	✗	✓	Positionnement prix différencié entre les marques <=> rentabilité
Pack Look XTR	✓	✓	Continuité de l'offre AC
GT Line	✗	✓	Positionnement marque. Homogénéité avec le reste de la gamme AP
Roues Alu 17"	✗	✓	Tendance marché, existant sur Caddy, cohérence GTLine, forte rentabilité
Modularité			
Vitres entrebaillantes	✓	✓	PRF pour versions d'accès.
Vitres descendantes	✗	✓	Incontournable ségment. Présent sur Kangoo, Tourneo, Doblo, Combo
Barres de toit modulaires	✓	✗	Enjeux développements / OS
Assises			
Siège passager fixe	✗	✓	Impacts PRF (-56€ sur VU entrée de gamme)
Siège passager escamotable	✗	✓	Modularité = critère d'achat n°1 sur le C1) : tuer l'USP de Kangoo
Autres			
Pneus 3PMSF	✗	✓	Livre blanc DEUR
Webasto	✗	✓	Faiblesse calorifique des €6.2
Parebrise chauffant	✗	✓	Compatibilité livre blanc DRUC
Diversité moyens de retenue (Airbag farside et latéraux R2, ceintures, papeterie de détection)	✗	✓	Grand écart eNCAP 2018 4* vs accessibilité PRF grand export

POWERTRAIN

Split between €0 and €6.3 !

PURE TECH
euro6
New European emission standards

110 (MT)
130 (AT)
110 (MT)

INTERNATIONAL
Euro4
Euro

BLUE HDi
euro6
New European emission standards 6.1 6.2

130 (AT)
100 (MT)
75 (MT)
90 (MT)
75 (MT)

INTERNATIONAL
Euro5
New European emission standards

New 8 automatic gearbox

Infinite variability of customers :
A range focused on uses !!!

L C V



PRO ABILITIES



SURROUND REAR VISION

GENERAL REAR OVERVIEW LATERAL VIEW PARKING REAR VIEW

USP



Ability to make a step up ! MPV killer !

Passenger Car



K9 PASSENGER CAR - BRANDS DIFFERENTIATION

Different line-up / Different price positioning

PRESERVE SEGMENT STANDARDS

Sliding doors - Boot size - Versatility



DIFFERENT STYLE AND BRAND MARKERS



MODULARITE – RANGEMENTS

Versatility and convenience reference !



5 ou 7pl en version
L1 & en version L2



+ 35 cm
en version L2

XTR Pack content

XTR

Shiny black on exterior rearview mirror



Front & rear
body color skid plate

Orange color

- on side moulding
- around front fog light

Alloy wheels 17' (16' with Grip Control)

Wild green Universe



L1 – L2



PRESS

- Clear perception of 3 different offers
- A real step forward in terms of performances and quality
- PSA group leadership in this segment claimed by press

... to be continued : LCV feedback expected soon and hopefully van of th Year !

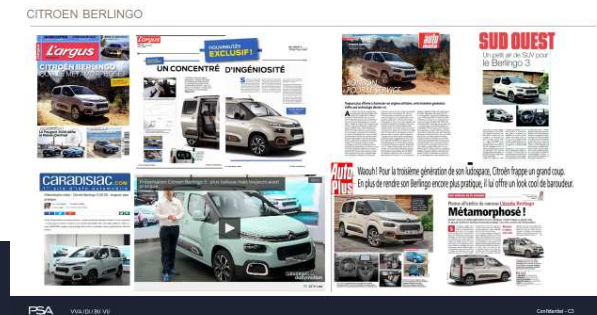



C5 AIRCROSS

*PRÉSENTATION SOCHAUX
31 OCTOBRE 2018*

Inspired by you

LE MARCHÉ (EUROPE)

- ▶ C-SUV EUROPE > 2 millions
- ▶ C-Monospace → C-SUV

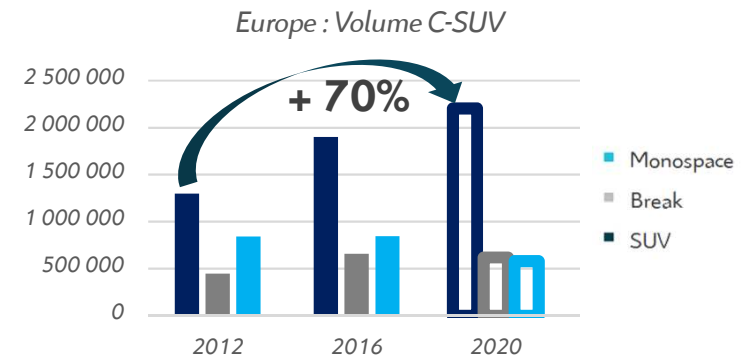

- ▶ 32 offres Concurrence

- ▶ C5 Aircross : dernier sur le marché → indispensable d'« Etre différent »

AU CŒUR DU SEGMENT

Prix

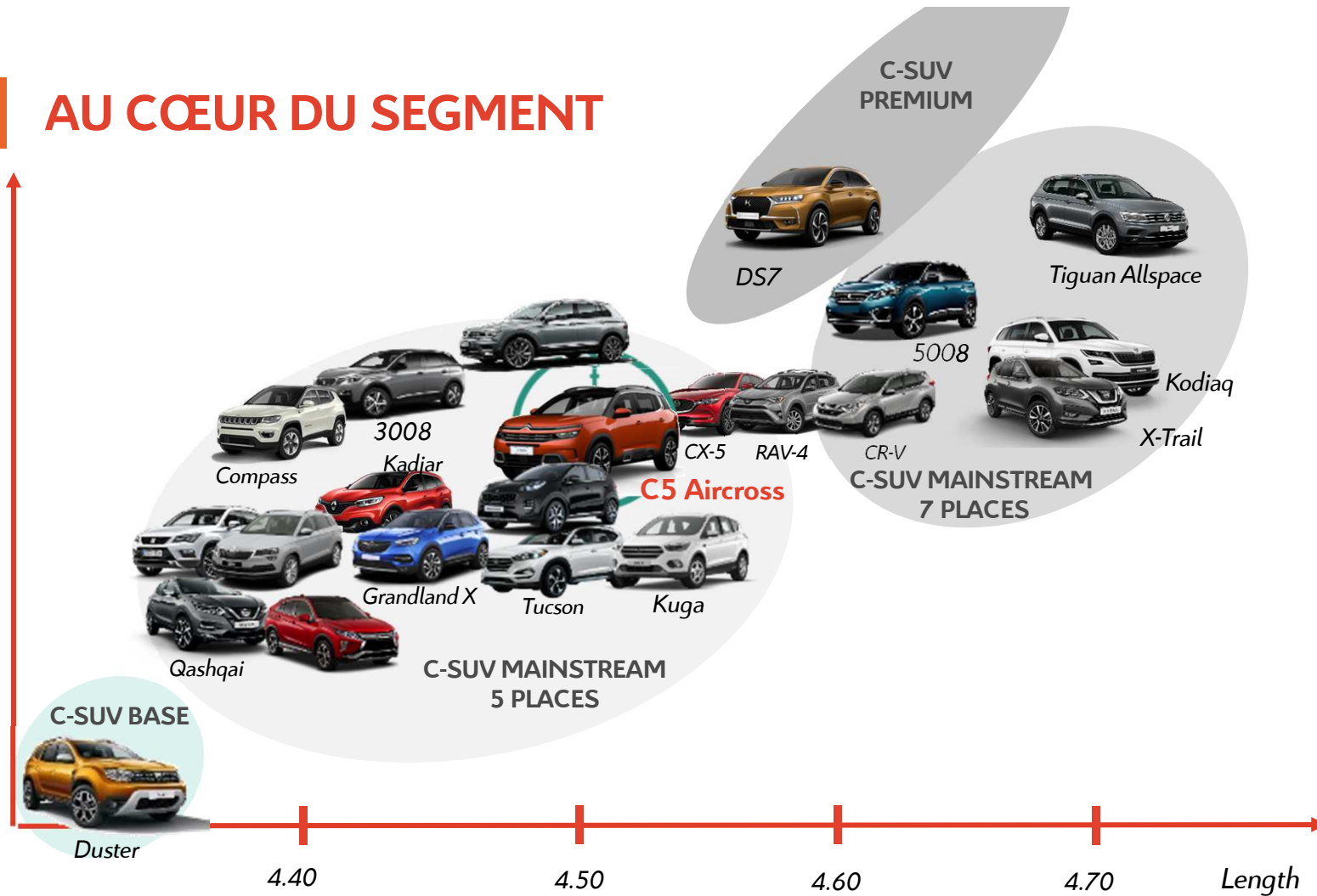

CIBLES CLIENTS C5 AIRCROSS

CONQUETE

- ▶ Attirer les clients SUV



FIDELITE

- ▶ Apporter une alternative **unique** aux clients monospace



PROVENANCE ACHETEURS C SUV MAINSTREAM – G5 2017

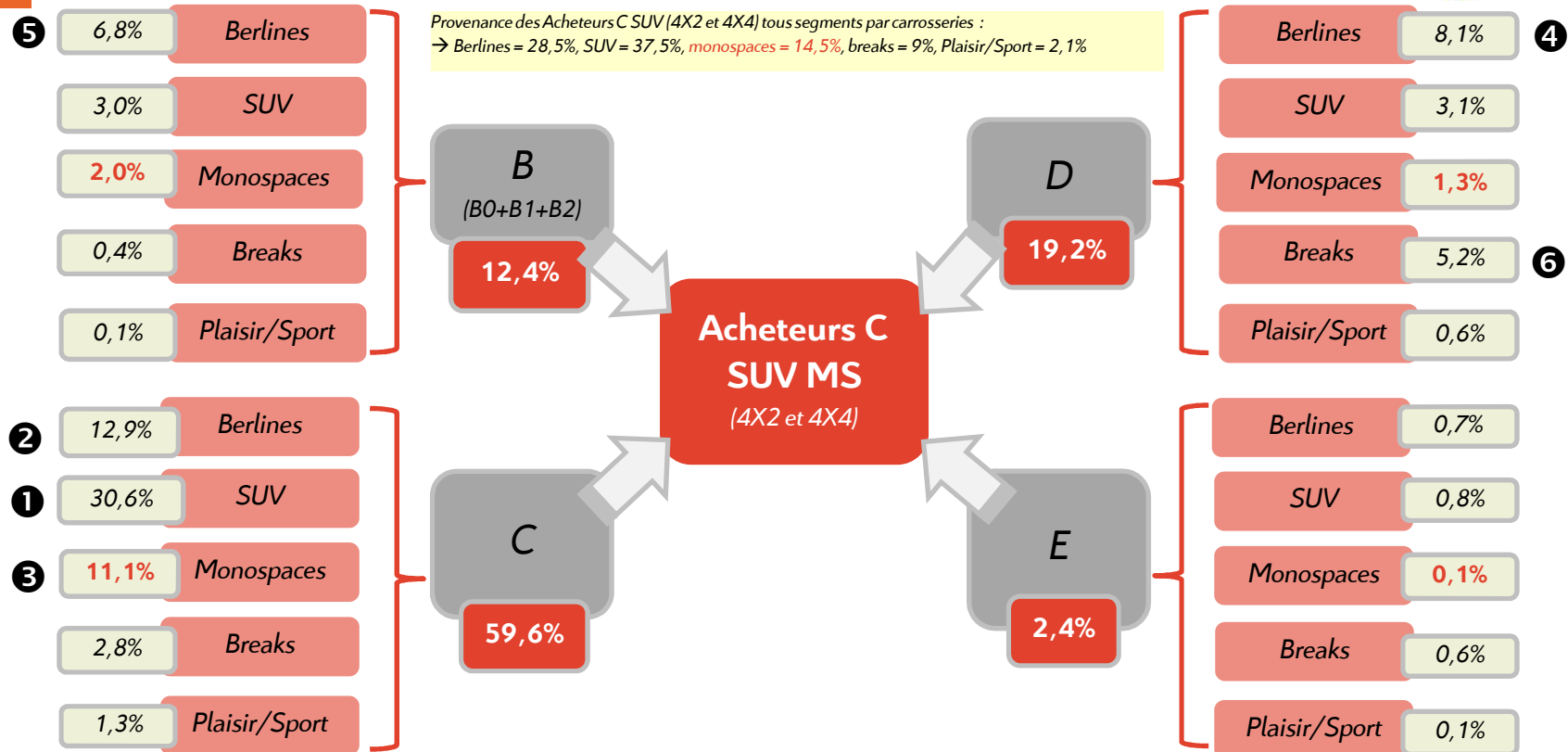

→ Attractivité tous segments, fort potentiel d'accompagnement de la descente en gamme du segment D

C5 AIRCROSS : NEW ANSWERS IN C- SUV SEGMENT

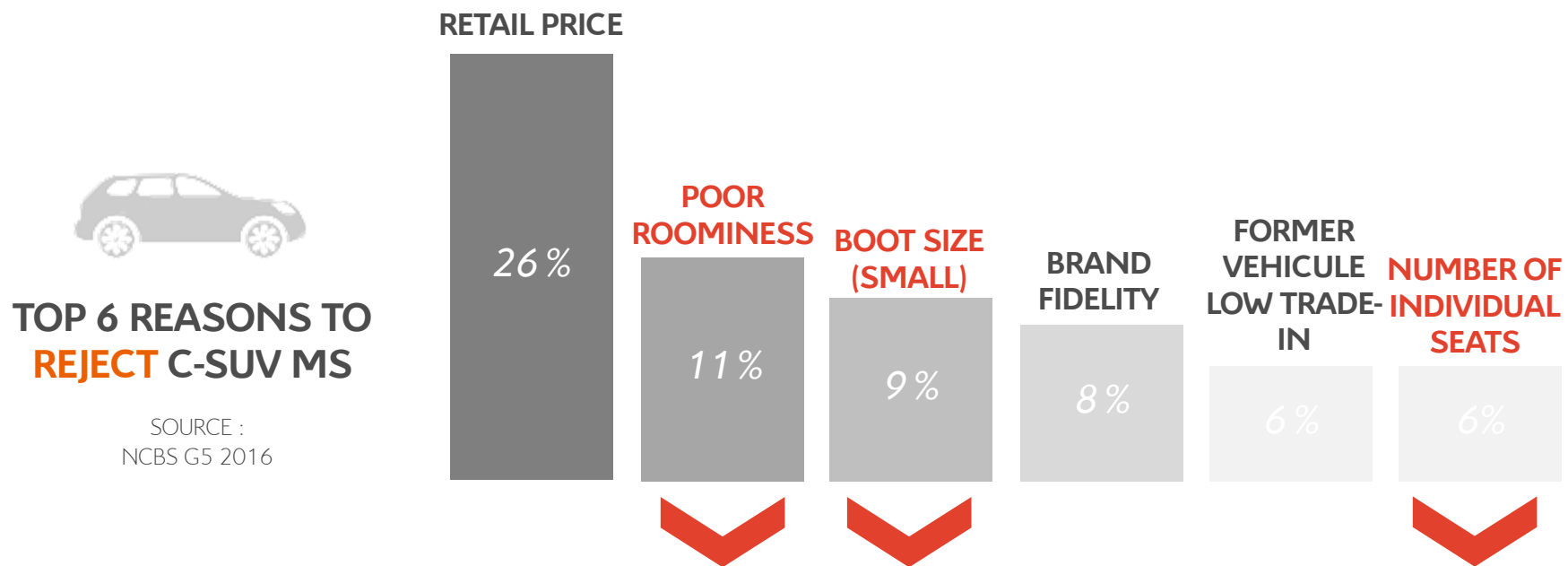

▶ C5 Aircross unique features = enlarged target

QUALIFICATION PRODUIT



C5 Aircross :

« Le SUV le plus **confortable** et **modulable** »

POINTS-CLE

« Le **SUV** le plus **confortable** et **modulable** »

#1 DESIGN



- ▼ Morphologie **SUV**
- ▼ Identité **Citroën**
- ▼ Offre de **personnalisation**

#2 CONFORT



- ▼ *Le SUV le **plus confortable***
- ▼ **Modularité** de monospace
- ▼ *Le plus grand **volume de coffre***

#3 TECHNO



- ▼ **20 Aides** à la conduite
- ▼ **Highway Driver Assist**
- ▼ **Plug-in Hybrid** (S1 2020)

SUV MORPHOLOGY

Inspired by you



SIDE PROFILE

Inspired by you

**HORIZONTAL
BONNET**

**BLACK
A PILLAR**

**COLOUR
DETAILING**

FLOATING ROOF

**LARGE WHEELS
DIAMETER = 720 MM**

**AIRBUMP® & 360°
PROTECTION**

**GROUND CLEARANCE
HEIGHT = 230 MM**



DIMENSIONS

Inspired by you



CUSTOMISATION

Inspired by you

7 BODY COLOURS



◇ POLAR WHITE



◆ PERLA NERA BLACK



◆ PLATINUM GREY



◆ CUMULUS GREY



◇ PEARL WHITE



◆ TIJUCA BLUE



◆ VOLCANO RED

3 COLOUR PACKS



ANODISED
WHITE



ANODISED
RED



ANODISED
SILVER

1 TWO-TONE ROOF



PERLA NERA BLACK

30
COMBINATIONS

Inspired by you



INTERIOR



CONFORT LE SUV LE PLUS CONFORTABLE ET MODULABLE

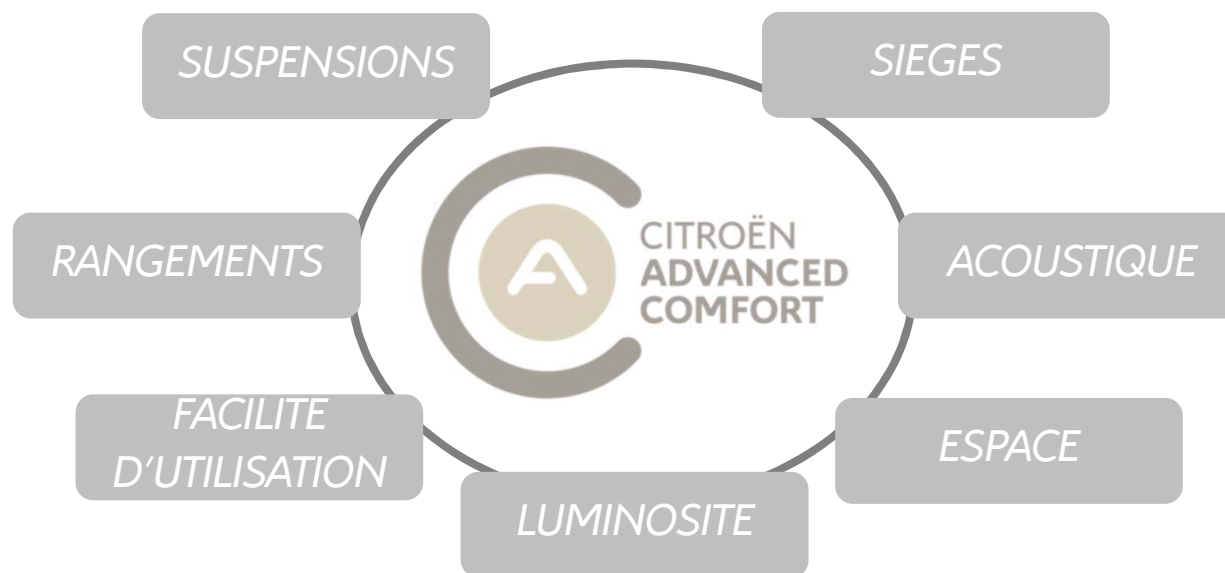



SUSPENSION WITH

**PROGRESSIVE
HYDRAULIC
CUSHIONS®**

Inspired by you





ADVANCED COMFORT *SEATS*

Inspired by you





3 SLIDING
**INDIVIDUAL
REAR SEATS**

Inspired by you



**COMFORT
BACKREST
5 POSITIONS
19° >>>> 26,5°**

**SLIDING
LENGTH
150 MM**





**THE BIGGEST
BOOT
VOLUME**
*OF THE
SEGMENT*

Inspired by you

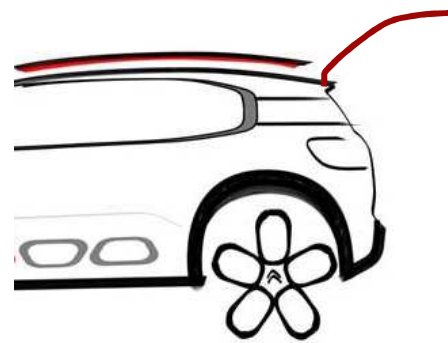

720l  **580l**



UP TO
1630 l



UP TO
1,90 m

PRODUCT KEY POINTS

« The most **comfortable** and **versatile C-SUV** »

#1 DESIGN



- ▼ **SUV Morphology**
- ▼ **Citroën Identity**
- ▼ **Customization Offer**

#2 CONFORT



- ▼ The **most comfortable SUV** USP
- ▼ **MPV-like versatility** USP
- ▼ **Biggest Boot size** USP

#3 TECHNO



- ▼ **20 ADAS**
- ▼ **Highway Driver Assist**
- ▼ **Plug-in Hybrid (S1 2020)**



**ADAPTIVE
CRUISE CONTROL
WITH
STOP & GO**

**HIGHWAY DRIVER
ASSIST**

Inspired by you



POWERTRAIN

Inspired by you

PURETECH

PETROL *Euro 6d-Temp*



PURETECH

130 S&S BVM6 (119-121 g/km*)

130 S&S EAT8 coming soon



PURETECH

180 S&S EAT8 (129-132 g/km*)

* NEDC

BLUE HDi

DIESEL *Euro 6d-Temp*



BLUEHDi

130 S&S BVM6 (106-109 g/km*)

130 S&S EAT8 (106-108 g/km*)



BLUEHDi

180 S&S EAT8 (124-128 g/km*)

**EAT8
AUTOMATIC
GEARBOX**

Inspired by you



C84E : EURO 6.2 ENGINES & WLTP VALUES

STANDARD

C84 €6.2 WLTP	Min	Max
Puretech 130 MT6	159	170
Puretech 180 eAT8	169	181
BlueHDI 130 MT6	138	149
BlueHDI 130 eAT8	141	151
BlueHDI 180 eAT8	164	175

C84 €6.2 NEDC Equivalent	17" & 18" Summer	18" M+S	19" T&N
Puretech 130 MT6	?	?	?
Puretech 180 eAT8	?	?	?
BlueHDI 130 MT6	108	109	106
BlueHDI 130 eAT8	107	108	106
BlueHDI 180 eAT8	126	128	124

MAIN OPTIONS

Equipement	CO ₂ Sensitivity
M+S 18" tire vs Summer 18" tire	2,1
18" (Summer tire) alloy wheel vs 17" alloy wheel	2,0
Panoramic sunroof (vs without)	1,0
Towing device	1,0
17" Alloy wheel Roue vs steel wheel + cover	0,5
Roof bars (vs without)	0,5
Temporary spare wheel vs repair kit	0,5
Ambience n°3 : Nappa leather seats with massage, driver's powered seat, FR heated seats	0,5
Ambience n°2 : half leather / fabric, driver's powered seat, FR heated seats	0,3
Hands free powered tailgate	0,1
Full LED FR lamps	0,1
Ambience n°2 : half leather / fabric, mechanical seats	0,1
Pack 5* (radar + ABSD)	0,0
19" T&N alloy wheel & tire vs 17" alloy	-1,3
19" T&N alloy wheel & tire vs 18" alloy Summer tire	-3,5

PLANNING DE LANCEMENT COMMERCIAL PRÉVISIONNEL

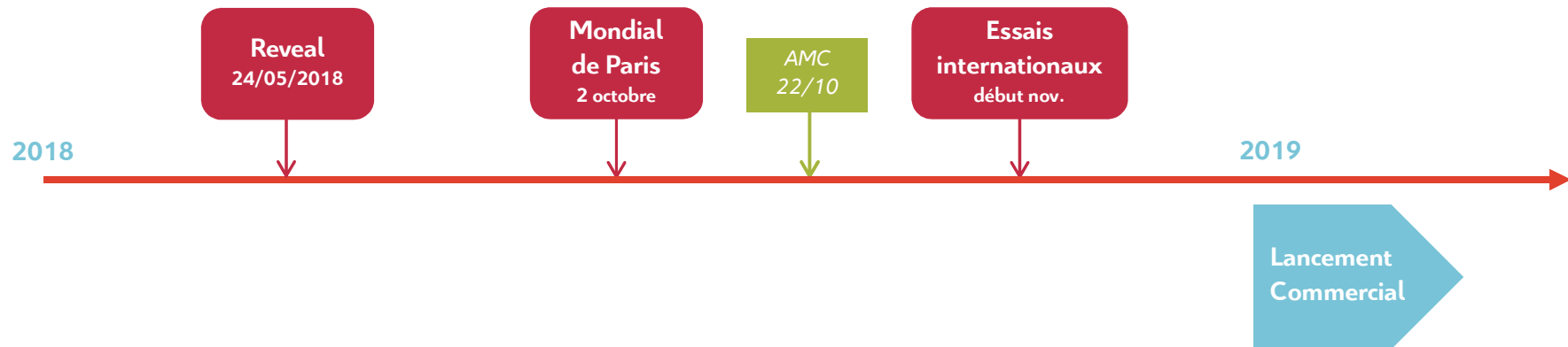

**PLUG-IN
HYBRID
BEGINNING
2020**

Inspired by you



**225 HP, 2WD
ZEV AUTONOMY (NEDC): 50 KM
<50 G/KM**

**ORIGINE
FRANCE
GARANTIE**

Inspired by you



**PRODUCED IN
RENNES – LA JANAIS**



SOLD IN 93 MARKETS

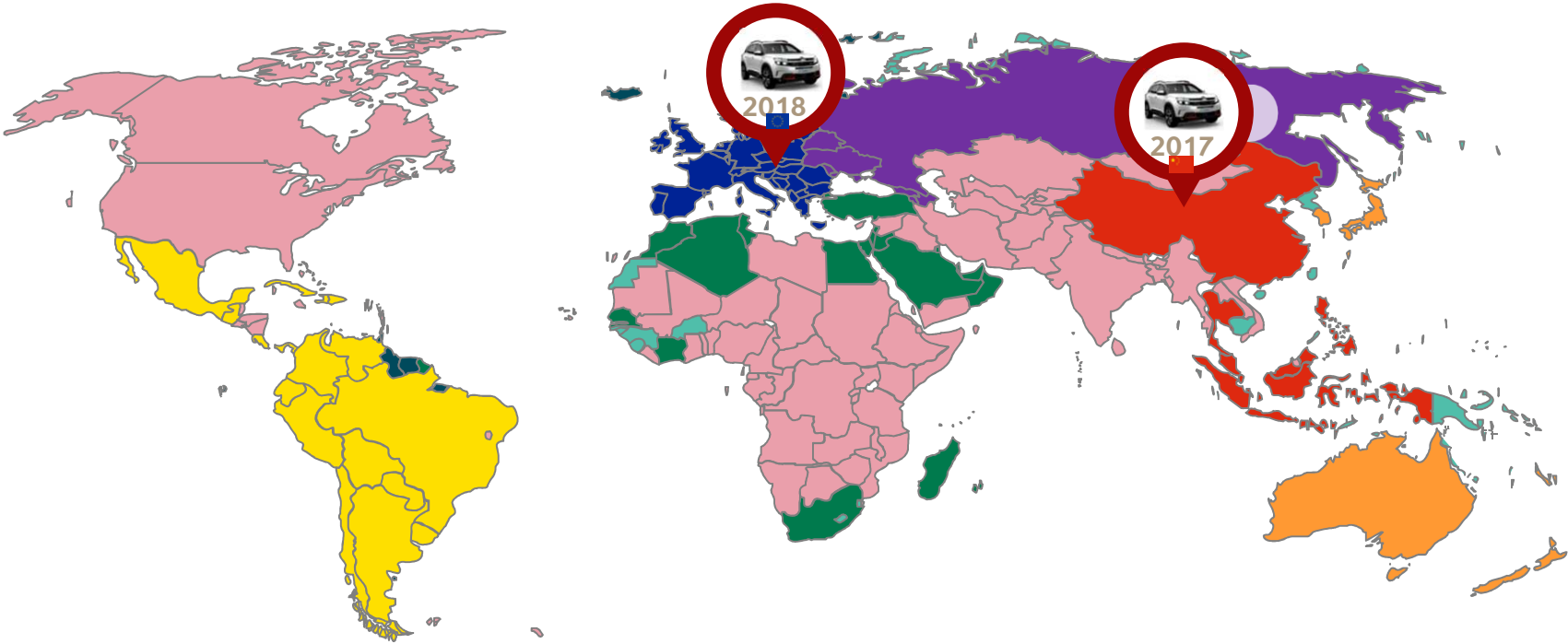



C5 AIRCROSS CHINE VS EUROPE



Inspired by you



- En résumé, les éléments changés :
- Taille de pneus en 19 "
 - Monogrammes
 - Canules débouchantes
 - GMP Chine: Essence BVA seulement

Différences entre versions Chinoises et Européennes:

- Volant 2 branches (Chine) VS volant 3 branches (Europe)
- Push de feux de détresse inversé

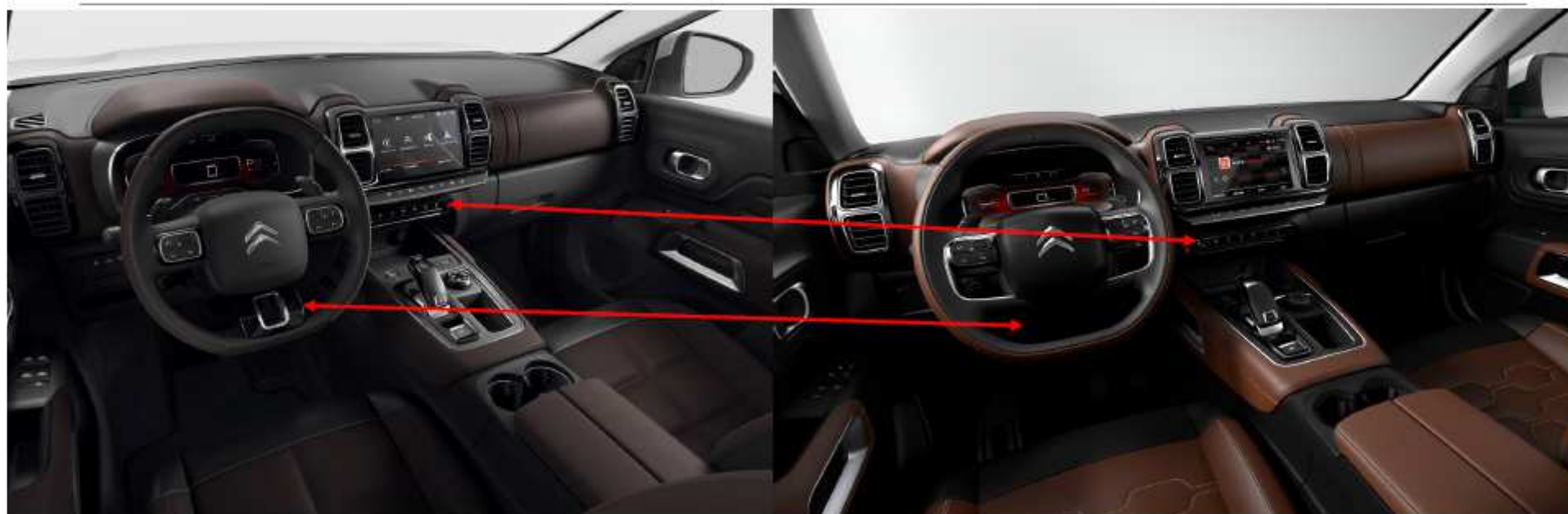

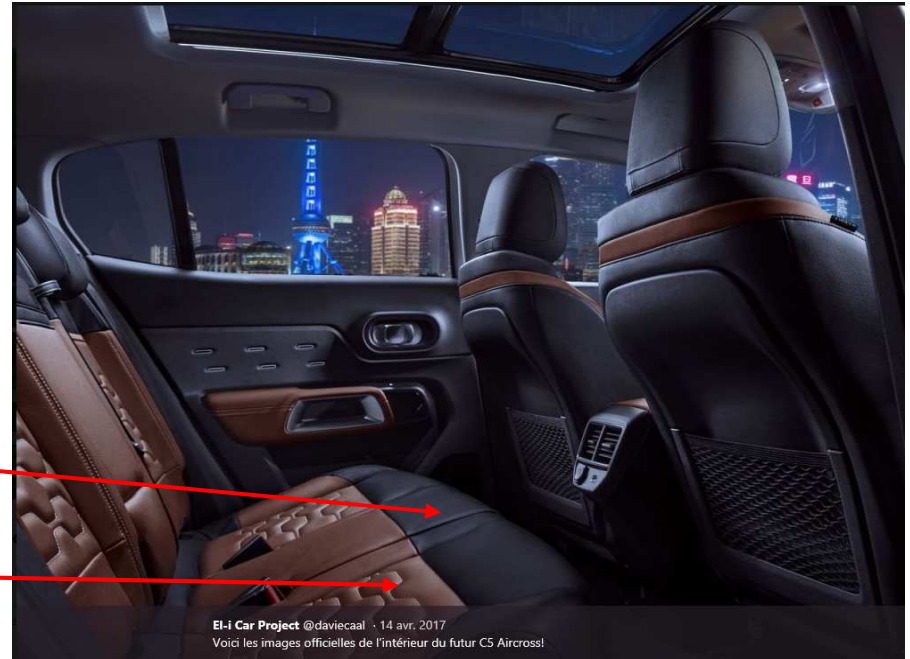

El-i Car Project @daviocaal · 14 avr. 2017
Voici les images officielles de l'intérieur du futur C5 Aircross!



Différences entre versions chinoises et Européennes:

- *Banquette arrière (chine) VS 3 sièges indépendants (Europe)*
- *Siège classique (Chine) VS sièges Advanced comfort®*



THANK YOU !

inspired by you

